

LONGITUDNAL COLD MILLING DETAIL
ALONG EXIST. CONC. CURB & GUTTER

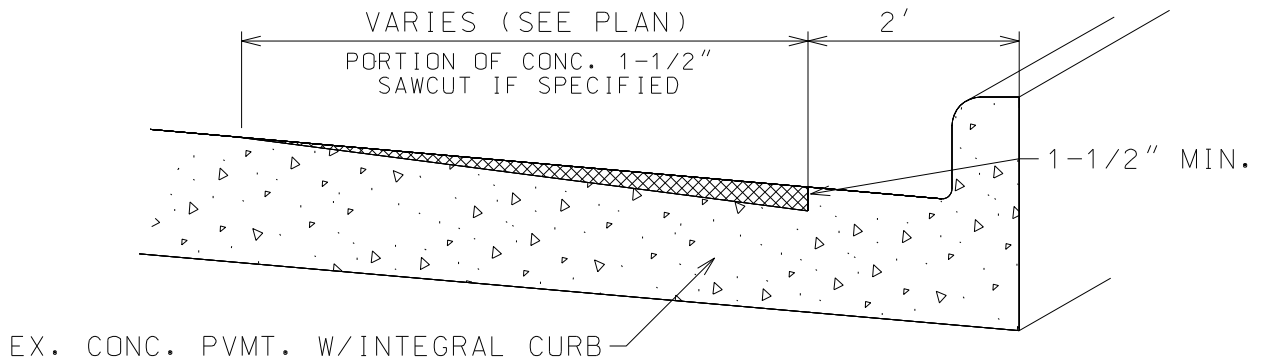

LONGITUDNAL COLD MILLING DETAIL
ALONG EXIST. CONC. PVMT. W/INTERGRAL CURB

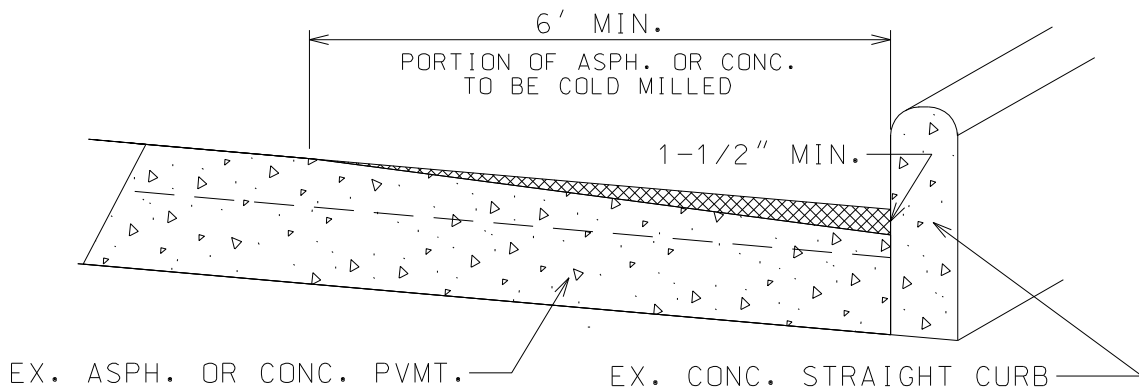

LONGITUDNAL COLD MILLING DETAIL
ALONG EXIST. SEPARATE CONC. CURB

| | | | | |
|-------------|---|-----|-----|------|
| P | P | | | |
| O | O | | | |
| N | N | | | |
| M | M | | | |
| L | L | | | |
| K | K | | | |
| J | J | | | |
| I | I | | | |
| H | H | | | |
| G | G | | | |
| F | F | | | |
| E | E | | | |
| D | D | | | |
| C | C | | | |
| B | B | | | |
| A | A | | | |
| DESCRIPTION | | DRW | CHK | DATE |

REVISIONS

CITY OF SOUTHFIELD STANDARD DETAIL

COLD MILLING FOR LONGITUDINAL BUTT JOINT

ISSUE: 2000

SD#: BR-7

SHEET: 1 OF 1

SCALE: N.T.S.

